



## Foreword

Read and understand this manual and the machine operator's manual before using your attachment. Keep it with the equipment at all times for future reference. If you sell your equipment, be sure to give this manual to the new owner.

If you need a replacement copy, contact your Ditch Witch® dealer. Visit our website at [www.ditchwitch.com](http://www.ditchwitch.com) or write to the following address:

The Charles Machine Works, Inc.  
Attn: Marketing Department  
PO Box 66  
Perry, OK 73077-0066  
USA

The descriptions and specifications in this manual are subject to change without notice. The Charles Machine Works, Inc. reserves the right to improve equipment. Some product improvements may have taken place after this manual was published. For the latest information on Ditch Witch equipment, see your Ditch Witch dealer.

### HF482/SK5PF Attachment Operator's Manual

Issue number 2.0/OM-7/2021  
Part number ID0443836

Copyright 2017, 2021  
by The Charles Machine Works, Inc.

 **Ditch Witch**® Ditch Witch is a registered trademark of The Charles Machine Works, Inc.

## Equipment Modification

This equipment was designed and built in accordance with applicable standards and regulations. Modification of equipment could mean that it will no longer meet regulations and may not function properly or in accordance with the operating instructions. Modification of equipment should only be made by competent personnel possessing knowledge of applicable standards, regulations, equipment design functionality/requirements and any required specialized testing.

## Intended Use

The HF482/SK5PF attachment is designed to be used outdoors to carry compact loads on top of the forks. It is not intended for lifting or carrying suspended loads.

## Safety Awareness

- Read and follow all safety precautions.
- Mark proposed path with white paint and have underground utilities located before working. In the US or Canada, call 811 (US) or 888-258-0808 (US and Canada). Also contact any local utilities that do not participate in the One-Call service. In countries that do not have a One-Call service, contact all local utility companies to have underground utilities located.
- Mark jobsite clearly and keep bystanders away.
- Wear personal protective equipment. Do not wear jewelry or loose clothing that can catch on controls.
- Use equipment carefully. Stop operation and investigate anything that does not look or feel right.
- Contact your Ditch Witch dealer if you have any question about operation, maintenance, or equipment use.
- Safety videos are available at [www.ditchwitch.com](http://www.ditchwitch.com) and from Ditch Witch dealers.

## Safety Alert Classifications

These classifications and the icons work together to alert you to situations which could be harmful to you, jobsite bystanders or your equipment. When you see these words and icons in the book or on the machine, carefully read and follow all instructions. **YOUR SAFETY IS AT STAKE.**

 **DANGER** indicates a hazardous situation that, if not avoided, will result in death or serious injury. This signal word is to be limited to the most extreme situations.

 **WARNING** indicates a hazardous situation that, if not avoided, could result in death or serious injury.

 **CAUTION** indicates a hazardous situation that, if not avoided, could result in minor or moderate injury.

**NOTICE** indicates information considered important, but not hazard-related (e.g., messages relating to property damage). **IMPORTANT** can help you do a better job or make your job easier in some way.



## Safety Alerts

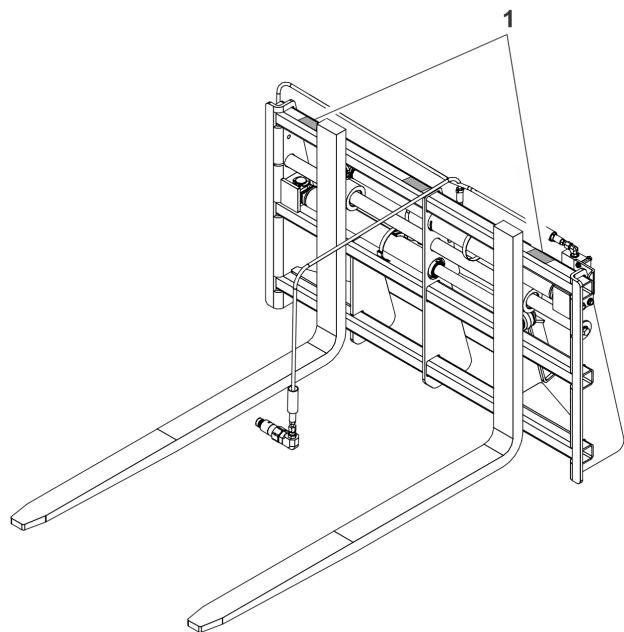

1



**WARNING** Moving parts.  
Contact can cause serious injury. Stay away.

## Transport

### Lift

Use a hoist capable of supporting the attachment's size and weight. See "Specifications" on page 5 or measure and weigh attachment before lifting.

## Controls

### Attachment Function

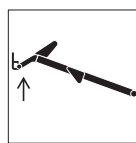

To raise forks, raise lift (loader) arms.

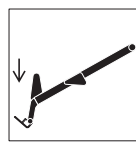

To lower forks, lower lift (loader) arms.

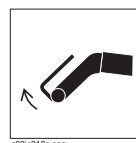

To curl/tilt forks up, tilt mount plate up.

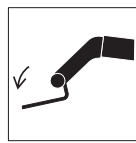

To curl/tilt forks down, tilt mount plate down.

To slide forks farther apart, engage attachment drive (auxiliary) in reverse (R).

To slide forks closer together, engage in forward (F).



## Connect Attachment

### Attachment

**IMPORTANT:** Before connecting attachment to machine, ensure that mount and receiver plates are free of dirt and debris and that latch handles are down.

1. Position attachment on level surface with enough space behind it to accommodate machine.

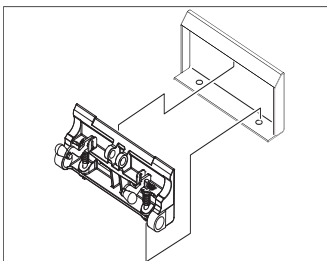

2. Start engine.
3. Tilt mount plate (2) forward.
4. Position mount plate in the upper lip of the receiver plate (1) on attachment.

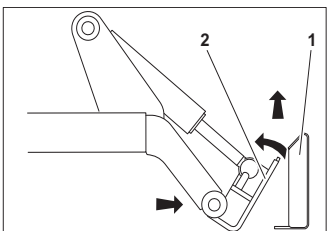

5. Raise lift arms while tilting back mount plate.

**IMPORTANT:** Attachment should be raised enough to clear the ground. Mount plate should be tilted back fully.

6. Pins will automatically engage.
7. Ensure lock pins are engaged by rotating attachment down. Verify that bottoms of lock pins are visible under attachment plate.

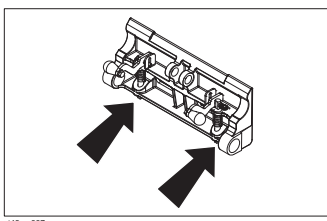

## Hydraulic Hoses



**WARNING** Pressurized fluid or air could pierce skin and cause injury or death. Stay away.

### To help avoid injury:

- Use a piece of cardboard or wood, rather than hands, to search for leaks.
- Wear protective clothing, including gloves and eye protection.
- Before disconnecting a hydraulic line, turn engine off and operate all controls to relieve pressure.
- Lower, block, or support any raised component with a hoist.
- Cover connection with heavy cloth and loosen connector nut slightly to relieve residual pressure. Catch all fluid in a container.
- Before using system, check that all connections are tight and all lines are undamaged.
- If you are injured, seek immediate medical attention from a doctor familiar with this type of injury.



**CAUTION** Hot parts may cause burns. Do not touch until cool or wear gloves.

**To help avoid injury:** Wear gloves when connecting and disconnecting hydraulic hoses and wait until machine has cooled before touching hydraulic components.

1. Remove dirt and debris from hydraulic couplers.
2. Connect male coupler on attachment to female coupler (3) on machine.
3. Connect female coupler on attachment to male coupler (1) on machine.

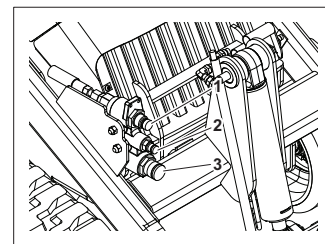

4. Ensure that connections are secure by pulling on hoses.



## Operate Attachment

### Adjusting Fork Position



**WARNING** Moving parts. Contact can cause serious injury. Stay away.

**To help avoid injury:** Keeps hands and feet away from moving parts.

1. Lower forks to just above ground.
2. Tilt forks back fully.
3. Use attachment drive (auxiliary) control to slide forks to desired position.

### Lifting



**WARNING** Lifted load. Crushing can cause death or serious injury. Stay away from lifted load and its range of movement.

**To help avoid injury:**

- Do not exceed the operating capacity of machine and attachment. Use lower number between the two.
- Do not walk or work under raised forks.
- Do not leave loaded forks raised, even if supports are used.
- Watch for holes, rocks, or other hazards when transporting a load. Inspect area before operation.

1. Align forks with pallet.
2. Move machine forward until fork frame is as close to pallet as possible.
3. Lift pallet of the ground.
4. Drive machine to move pallet to new location.

#### **IMPORTANT:**

- Keep fork as close to the ground as possible when transporting a load.
  - Keep load level.
5. Lower pallet to ground.
  6. Move machine backward until forks clear pallet.



## Storage

Store attachment upright in a clean, dry place. Cover attachment to keep it clean.

## Service

**To help avoid injury:** Unless otherwise noted, all service should be performed with the engine off.

## 10-Hour

### Check Hydraulic Hoses and Fittings

Check hydraulic hoses for leaks every 10 hours.

## Specifications

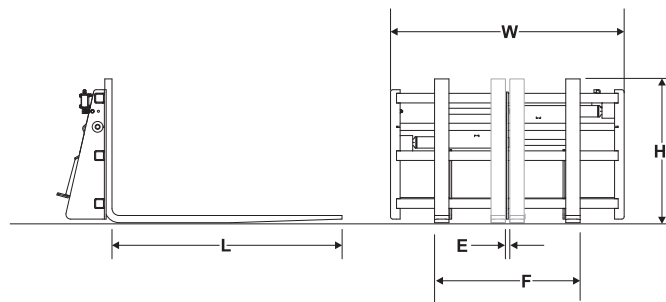

a58om001h.eps

Dimensions		U.S.	Metric
E	Spread, min	1.5in	38.1mm
F	Spread, max	39.5in	1m
H	Height	30in	762mm
L	Length, fork	48in	1.2m
W	Width, frame	48.75in	1.2m
	Width, fork	3in	76.2mm
Attachment mass, no blade		428lb	194kg

Performance		U.S.	Metric
Capacity @ 24" (610mm) from front edge of fork		1900lb	861.8kg
Capacity, max.		3800lb	1723.7kg

Specifications are called out according to SAE recommended procedures. Specifications are general and subject to change without notice. If exact measurements are required, equipment should be weighed and measured.



## Support

### Procedure

Notify your dealer immediately of any malfunction or failure of Ditch Witch® equipment.

Always give model, serial number, and approximate date of your equipment purchase. This information should be recorded and placed on file by the owner at the time of purchase.

Return damaged parts to dealer for inspection and warranty consideration if in warranty time frame.

Order genuine Ditch Witch replacement or repair parts from your authorized Ditch Witch dealer. Use of another manufacturer's parts may void warranty consideration.

### Serial Number Plate

1. Serial number
2. Attachment weight
3. Date of manufacture

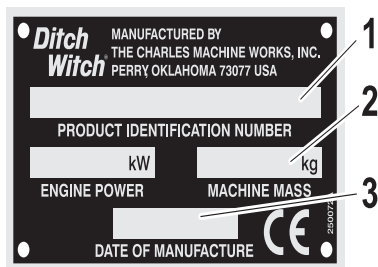

## Resources

### Publications

Contact your Ditch Witch dealer for publications and videos covering safety, operation, service, and repair of your equipment.

### Ditch Witch Training

For information about on-site, individualized training, contact your Ditch Witch dealer.

## Warranty

### Ditch Witch® Equipment and Replacement Parts Limited Warranty Policy

Subject to the limitation and exclusions herein, free replacement parts will be provided at any authorized Ditch Witch dealership for any Ditch Witch equipment or parts manufactured by the Ditch Witch factory that fail due to a defect in material or workmanship within one (1) year of first commercial use. Free labor will be provided at any authorized Ditch Witch dealership for installation of parts under this warranty during the first year following "initial commercial" use of the serial-numbered Ditch Witch equipment on which it is installed. The customer is responsible for transporting their equipment to an authorized Ditch Witch dealership for all warranty work.

### Exclusions from Product Warranty

- All incidental or consequential damages.
- All defects, damages, or injuries caused by misuse (including, but not limited to, rollover), abuse, improper installation, alteration, neglect, or uses other than those for which products were intended.
- All defects, damages, or injuries caused by improper training, operation, or servicing of products in a manner inconsistent with manufacturer's recommendations.
- All engines and engine accessories (these are covered by original manufacturer's warranty).
- Tires, belts, and other parts which may be subject to another manufacturer's warranty (such warranty will be available to purchaser).
- ALL IMPLIED WARRANTIES NOT EXPRESSLY STATED HEREIN, INCLUDING ANY WARRANTY OF FITNESS FOR A PARTICULAR PURPOSE AND MERCHANTABILITY.

IF THE PRODUCTS ARE PURCHASED FOR COMMERCIAL PURPOSES, AS DEFINED BY THE UNIFORM COMMERCIAL CODE, THEN THERE ARE NO WARRANTIES WHICH EXTEND BEYOND THE FACE HEREOF AND THERE ARE NO IMPLIED WARRANTIES OF ANY KIND WHICH EXTEND TO A COMMERCIAL BUYER. ALL OTHER PROVISIONS OF THIS LIMITED WARRANTY APPLY INCLUDING THE DUTIES IMPOSED.

Ditch Witch products have been tested to deliver acceptable performance in most conditions. This does not imply they will deliver acceptable performance in all conditions. Therefore, to assure suitability, products should be operated under anticipated working conditions prior to purchase.

Defects will be determined by an inspection within thirty (30) days of the date of failure of the product or part by Ditch Witch Product Support (DWPS) or its authorized dealer. DWPS will provide the location of its inspection facilities or its nearest authorized dealer upon inquiry. DWPS reserves the right to supply remanufactured replacement parts under this warranty as it deems appropriate.

Extended warranties are available upon request from your local Ditch Witch dealer or the Ditch Witch factory.

Some states do not allow exclusion or limitation of incidental or consequential damages, so above limitation of exclusion may not apply. Further, some states do not allow exclusion of or limitation of how long an implied warranty lasts, so the above limitation may not apply. This limited warranty gives product owner specific legal rights and the product owner may also have other rights which vary from state to state.

For information regarding this limited warranty, contact the DWPS department, P.O. Box 66, Perry, OK 73077-0066, or contact your local dealer.

First version: 1/91; Latest version: 7/19